

* incl. 20 [-5; +30] mm pull out

3D model is available on request or www.hyva.com

Specifications		Max. pump flow		Tipping time	
Max. working pressure	170 bar	With KO ¹	190 L/min	With KO ¹	25 sec
Weight	237 kg	Without KO ¹	162 L/min	Without KO ¹	30 sec
Working volume	80 L	With KO ¹ below -20°C	133 L/min	With KO ¹ below -20°C	36 sec
Total volume	87 L	Without KO ¹ below -20°C	113 L/min	Without KO ¹ below -20°C	43 sec
Max. cyl. load (start tipping)	345 kN			Allowable lowering time	25 sec
Max. cyl. load (end of stroke) ²	94 kN				
Max. cyl. load (end of stroke) ³	109 kN				

Technical notes

- This cylinder is a lifting device only.
- It should not be used as a structural member and should not be subjected to side loads.
- Tipping valve must have a pressure relief at the cylinder port set not higher than max. working pressure.
- Verify max. cyl. load.
- Working temperature range is between -40°C and +80°C.
- Max. duration of extension is 0.5 hours (excluded hard chromed stages).
- Cylinder is painted black (RAL9005) with a min. thickness conforming to the 480 hours neutral salt spray test as per ISO 9227.
- ¹ Hyva knock-off.
- ² Unsubstantial unloading (sticky load).
- ³ Substantial unloading.

Related documentation

Bracket options:	015BRA10 & 015BRA13
Mounting instructions:	CYL-0031
Oil specifications:	OIL-0011
Spec sheet explanation:	CYL-0041

Configuration

Extension	1	2	3	4	5	6	7	Total
Effective diameter [mm]	157	137	118	99				
Stroke* [mm]	1510	1530	1530	1530				6100

Tipping weight

For detailed tipping calculations please refer to: <https://tipper.hyva.com>

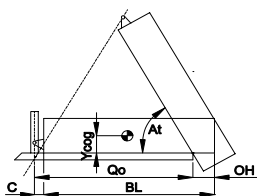

BL body length
OH rear overhang
Ycog vert. pos. centre of gravity
Qo pivot length
C bracket length
At tipping angle
stroke x 60 / Qo

BL [mm]	8000			7700			7400		
OH [mm]	200	500	800	200	500	800	200	500	800
At [°]	46	48	50	48	50	53	50	53	55
Ycog [mm]	600			900			1200		
	35	38	41	36	39	42	37	40	44
	37	40	44	38	42	47	40	44	50
	40	44	49	41	46	52	43	49	57

Tipping weight [ton] at maximum pressure of 170 bar for a vertically mounted cylinder and C is 158 mm

Pos.	Part no.	Description	Qty.
C01	71839121	DUST COVER FE 149-4/157-4	1
P01	70433723	PISTON MN3 S 099-1785-HC	1
P02	70209310K	SLIDER MN 099 (2 x 1/2) A22	1
P03	70216099K	OUTER STOPRING MN 099 A22	1
P04	70224099	BOTTOM PLATE PISTON MN 099	1
P05	01770580K	CIRCLIP 90 DIN 472 (95.5x3.5)	1
P06	70260215K	O-RING PISTON BOTTOM 099	1
P07	70235400	PISTON EYE SPH. MN3 099 L=075	1
P08	70260115K	O-RING 82.14 X 3.53 MM	1
P09	71875450K	SPHERICAL BEARING D.50.3 MAINT. FREE	1
P10	01770560K	CIRCLIP 75 DIN 472 (79.5x2.5)	1
P11	71875012	PIN ROUND HEAD GROOVED 8x15 mm	2

S31	70664720	STAGE MN2 118-1780	1
S32	70203118K	PACKSET MN 118	1
S33	70209320K	SLIDER MN 118 (2 x 1/2) A22	1
S34	70216118K	OUTER STOPRING MN 118 A22	1
S35	70217118K	LIFTRING MN 118 A22	1

S21	70665720	STAGE MN2 137-1780	1
S22	70203137K	PACKSET MN 137	1
S23	70207137K	SLIDER MN 137 A35	1
S24	70216137K	OUTER STOPRING MN 137 A22	1
S25	70217137K	LIFTRING MN 137 A22	1

S11	70666720	STAGE MN2 157-1780	1
S12	70203157K	PACKSET MN 157	1
S13	70207157K	SLIDER MN 157 A35	1
S14	70216157K	OUTER STOPRING MN 157 A22	1
S15	70213157K	LIFTRING MN 157x5 MK2	1

B01	70367724	BASE MN2 179-1823-4/4BSAE-290	1
B02	70203179K	PACKSET MN 179	1
B03	70225360	BOTTOM PLATE MN2 179	1
B04	70270179K	SEAL BOTTOM PLATE MN 179	1
B05	70220185	LOCKING PLATE MN2 179	3
B06	01732055K	BOLT HEX M8X20X1.25 SET 6 PCS	1
B07	01732559K	WASHER SPRING M8 SET 6 PCS	1

Seal kit complete

71907640K	Consists of all packsets with packset grease and O-rings
-----------	--

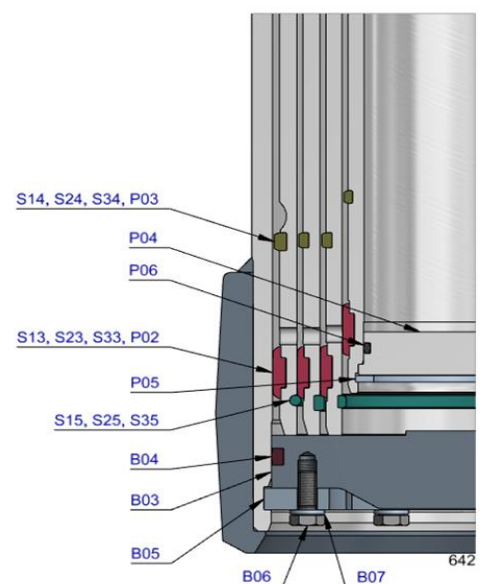
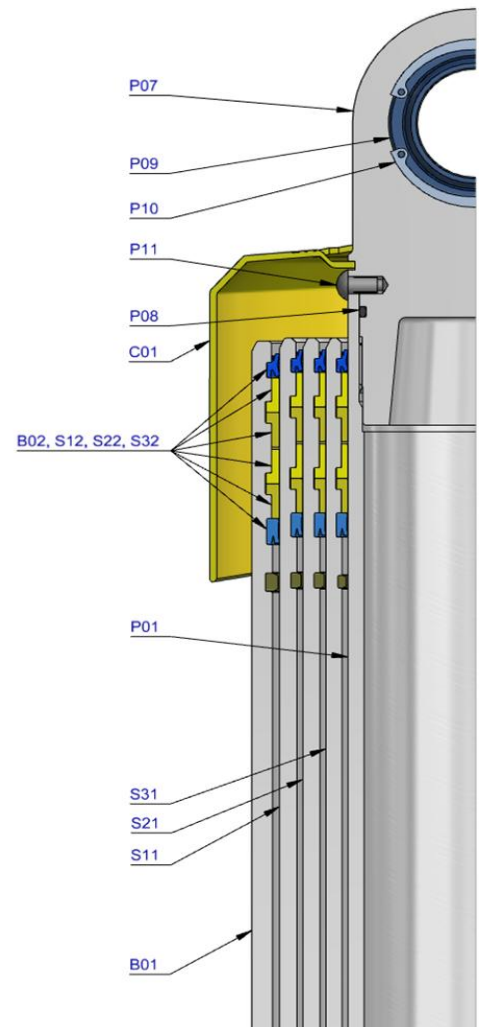

Notes

The inner stopring and piston bottom are pre-mounted on spare bases, stage and pistons. Therefore, when ordering new tubes, it is not required to order these parts separately.

For repair instructions see: CYL-0040. Serial no. is located on type plate and near type plate support.