

* incl. 20 [-5; +30] mm pull out

3D model is available on request or www.hyva.com

Specifications		Max. pump flow		Tipping time	
Max. working pressure	150 bar	With KO ¹	190 L/min	With KO ¹	39 sec
Weight	399 kg	Without KO ¹	137 L/min	Without KO ¹	54 sec
Working volume	124 L	With KO ¹ below -20°C	133 L/min	With KO ¹ below -20°C	56 sec
Total volume	135 L	Without KO ¹ below -20°C	96 L/min	Without KO ¹ below -20°C	77 sec
Max. cyl. load (start tipping)	245 kN			Allowable lowering time	39 sec
Max. cyl. load (end of stroke) ²	70 kN				
Max. cyl. load (end of stroke) ³	82 kN				

Technical notes

- This cylinder is a lifting device only.
- It should not be used as a structural member and should not be subjected to side loads.
- Tipping valve must have a pressure relief at the cylinder port set not higher than max. working pressure.
- Verify max. cyl. load.
- Working temperature range is between -40°C and +80°C.
- Max. duration of extension is 0.5 hours (excluded hard chromed stages).
- Cylinder is painted black (RAL9005) with a min. thickness conforming to the 480 hours neutral salt spray test as per ISO 9227.
- ¹ Hyva knock-off.
- ² Unsubstantial unloading (sticky load).
- ³ Substantial unloading.

Related documentation

- Bracket options: 015BRA10 & 015BRA12
- Mounting instructions: CYL-0030
- Oil specifications: OIL-0011
- Spec sheet explanation: CYL-0041

Configuration

Extension	1	2	3	4	5	6	7	Total
Effective diameter [mm]	169	149	129	110	91			9030
Stroke* [mm]	1790	1810	1810	1810	1810			

Tipping weight

For detailed tipping calculations please refer to: <https://tipper.hyva.com>

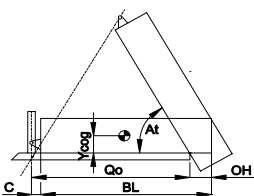

- BL body length
- OH rear overhang
- Ycog vert. pos. centre of gravity
- Qo pivot length
- C bracket length
- At tipping angle

BL [mm]	12000			11500			11000		
OH [mm]	200	500	800	200	500	800	200	500	800
At [°]	44	46	47	46	48	49	49	50	52
Ycog [mm]									
600	26	27	28	26	28	29	27	29	30
900	27	28	30	27	29	31	28	30	32
1200	28	29	31	29	31	33	30	32	35

Tipping weight [ton] at maximum pressure of 150 bar for a vertically mounted cylinder and C is 229 mm

Pos.	Part no.	Description	Qty.
C01	71839040	DUST COVER FC LOW 15-244	1
C02	71706550	COVER 242-1335 PIN60 A340 FIX	1
C03	01702956K	WASHER M48 DIN 125B ZP	1
C04	01702907K	TOPNUT NYLOC M48x3 DIN 985 ZP	1
P01	74462871	PISTON FL3 S 091-2095-HC	1
P02	71853091K	SLIDER FL 091 (2 X 1/2) A22	1
P03	71851091K	OUTER STOPRING FL 091 A22	1
P04	71822091	BOTTOM PLATE PISTON FL 091	1
P05	01745012K	CIRCLIP 82 DIN 472 (87.5x2.5)	1
P06	71870215K	O-RING PISTON BOTTOM 091	1
P07	71848200	PISTON HEAD FL3 091	1
P08	01226430K	O-RING 72.62 X 3.53 MM	1

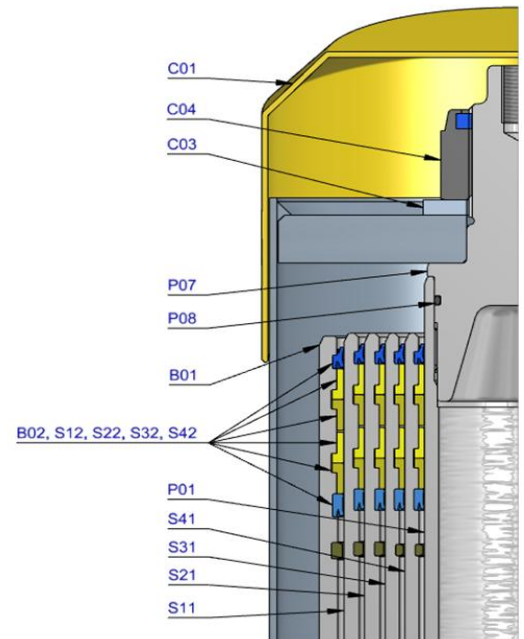

S41	74603871	STAGE FL2 110-2090-HC	1
S42	71802110K	PACKSET FL 110	1
S43	71853110K	SLIDER FL 110 (2 X 1/2) A22	1
S44	71851110K	OUTER STOPRING FL 110 A22	1
S45	71852110K	LIFTRING FL 110 A22	1

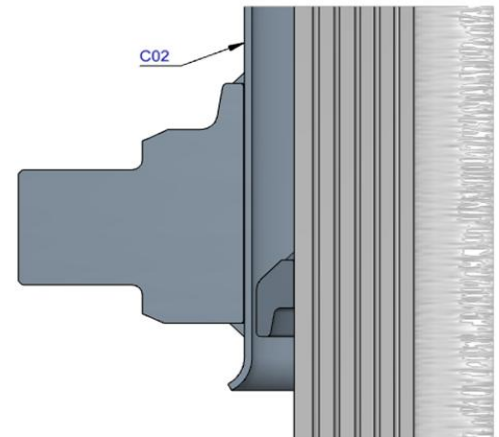

S31	74604871	STAGE FL2 129-2090-HC	1
S32	71802129K	PACKSET FL 129/HP 129	1
S33	71853129K	SLIDER FL 129 (2 X 1/2) A22	1
S34	71851129K	OUTER STOPRING FL 129 A22	1
S35	71852129K	LIFTRING FL 129 A22	1

S21	74605871	STAGE FL2 149-2090-HC	1
S22	71802149K	PACKSET FL 149/HP 150	1
S23	71807151K	SLIDER FL 149 A35	1
S24	71851149K	OUTER STOPRING FL 149 A22	1
S25	71852149K	LIFTRING FL 149 A22	1

S11	74606871	STAGE FL2 169-2090-HC	1
S12	71802169K	PACKSET FL 169	1
S13	71807171K	SLIDER FL 169 A35	1
S14	71851169K	OUTER STOPRING FL 169 A22	1
S15	71813169K	LIFTRING FL 169x5	1

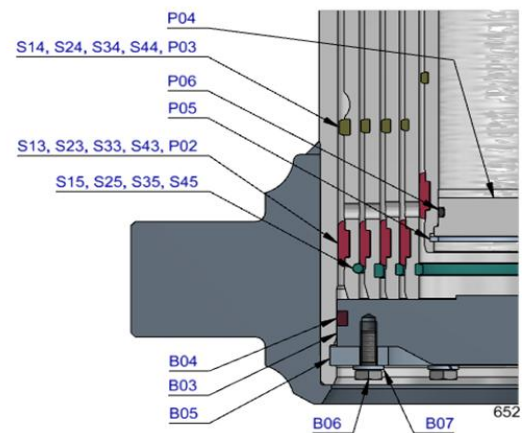

B01	74507872R1235	BASE FL2 191-2133-4/4BSAE-290-90-C242	1
B02	71802191K	PACKSET FL 191	1
B03	71825430	BOTTOM PLATE FL2 191	1
B04	71870040K	SEAL BOTTOM PLATE FL 191	1
B05	71820195	LOCKING PLATE FL2 191	3
B06	01732055K	BOLT HEX M8X20X1.25 SET 6 PCS	1
B07	01732559K	WASHER SPRING M8 SET 6 PCS	1

Seal kit complete

71908650K	Consists of all packsets with packset grease and O-rings
-----------	--

Notes

The inner stopring and piston bottom are pre-mounted on spare bases, stage and pistons. Therefore, when ordering new tubes, it is not required to order these parts separately.

For repair instructions see: CYL-0040. Serial no. is located on type plate and near type plate support.