

* incl. 20 [-5; +30] mm pull out

3D model is available on request or www.hyva.com

Specifications		Max. pump flow		Tipping time	
Max. working pressure	250 bar	With KO ¹	190 L/min	With KO ¹	17 sec
Weight	171 kg	Without KO ¹	137 L/min	Without KO ¹	24 sec
Working volume	54 L	With KO ¹ below -20°C	133 L/min	With KO ¹ below -20°C	24 sec
Total volume	59 L	Without KO ¹ below -20°C	96 L/min	Without KO ¹ below -20°C	34 sec
Max. cyl. load (start tipping)	245 kN			Allowable lowering time	17 sec
Max. cyl. load (end of stroke) ²	128 kN				
Max. cyl. load (end of stroke) ³	149 kN				

Technical notes

- This cylinder is a lifting device only. • It should not be used as a structural member and should not be subjected to side loads. • Tipping valve must have a pressure relief at the cylinder port set not higher than max. working pressure. • Verify max. cyl. load. • Working temperature range is between -40°C and +80°C. • Max. duration of extension is 0.5 hours (excluded hard chromed stages). • Cylinder is painted black (RAL9005) with a min. thickness conforming to the 480 hours neutral salt spray test as per ISO 9227. • ¹ Hyva knock-off. • ² Unsubstantial unloading (sticky load). • ³ Substantial unloading.

Related documentation

- Bracket options: O15BRA10 & O15BRA13
- Mounting instructions: CYL-0031
- Oil specifications: OIL-0011
- Spec sheet explanation: CYL-0041

Configuration

Extension	1	2	3	4	5	6	7	Total
Effective diameter [mm]	149	129	110	91				4660
Stroke* [mm]	1150	1170	1170	1170				

Tipping weight

For detailed tipping calculations please refer to: <https://tipper.hyva.com>

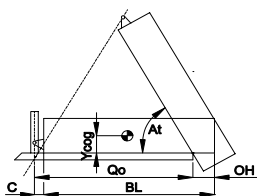

- BL body length
 - OH rear overhang
 - Ycog vert. pos. centre of gravity
 - Qo pivot length
 - C bracket length
 - At tipping angle
- stroke x 60 / Qo*

BL [mm]	OH [mm]	At [°]	Ycog [mm]	200	500	800	200	500	800	200	500	800
600	45	45	45	45	45	45	45	45	45	45	45	45
900	49	49	49	49	49	49	49	49	49	49	49	49
1200	51	51	51	51	51	51	51	51	51	51	51	51

Tipping weight [ton] at maximum pressure of 250 bar for a vertically mounted cylinder and C is 158 mm

Pos.	Part no.	Description	Qty.
C01	71839121	DUST COVER FE 149-4/157-4	1
P01	74462371	PISTON FL3 S 091-1365-HC	1
P02	71853091K	SLIDER FL 091 (2 X 1/2) A22	1
P03	71851091K	OUTER STOPRING FL 091 A22	1
P04	71822091	BOTTOM PLATE PISTON FL 091	1
P05	01745012K	CIRCLIP 82 DIN 472 (87.5x2.5)	1
P06	71870215K	O-RING PISTON BOTTOM 091	1
P07	71847200	PISTON EYE SPH. FL3 091 L=075	1
P08	01226430K	O-RING 72.62 X 3.53 MM	1
P09	71875450K	SPHERICAL BEARING D.50.3 MAINT. FREE	1
P10	01770560K	CIRCLIP 75 DIN 472 (79.5x2.5)	1
P11	71875012	PIN ROUND HEAD GROOVED 8x15 mm	2

S31	74603370	STAGE FL2 110-1360	1
S32	71802110K	PACKSET FL 110	1
S33	71853110K	SLIDER FL 110 (2 X 1/2) A22	1
S34	71851110K	OUTER STOPRING FL 110 A22	1
S35	71852110K	LIFTRING FL 110 A22	1

S21	74604370	STAGE FL2 129-1360	1
S22	71802129K	PACKSET FL 129/HP 129	1
S23	71853129K	SLIDER FL 129 (2 X 1/2) A22	1
S24	71851129K	OUTER STOPRING FL 129 A22	1
S25	71852129K	LIFTRING FL 129 A22	1

S11	74605370	STAGE FL2 149-1360	1
S12	71802149K	PACKSET FL 149/HP 150	1
S13	71807151K	SLIDER FL 149 A35	1
S14	71851149K	OUTER STOPRING FL 149 A22	1
S15	71852149K	LIFTRING FL 149 A22	1

B01	74506370	BASE FL2 169-1399-4/4BSAE-190	1
B02	71802169K	PACKSET FL 169	1
B03	71825425	BOTTOM PLATE FL2 169	1
B04	71870035K	SEAL BOTTOM PLATE FL 169	1
B05	71820169	LOCKING PLATE FL 169	3
B06	01732055K	BOLT HEX M8X20X1.25 SET 6 PCS	1
B07	01732559K	WASHER SPRING M8 SET 6 PCS	1

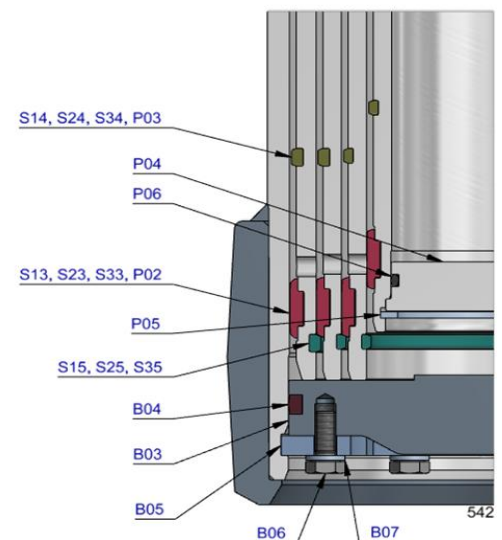
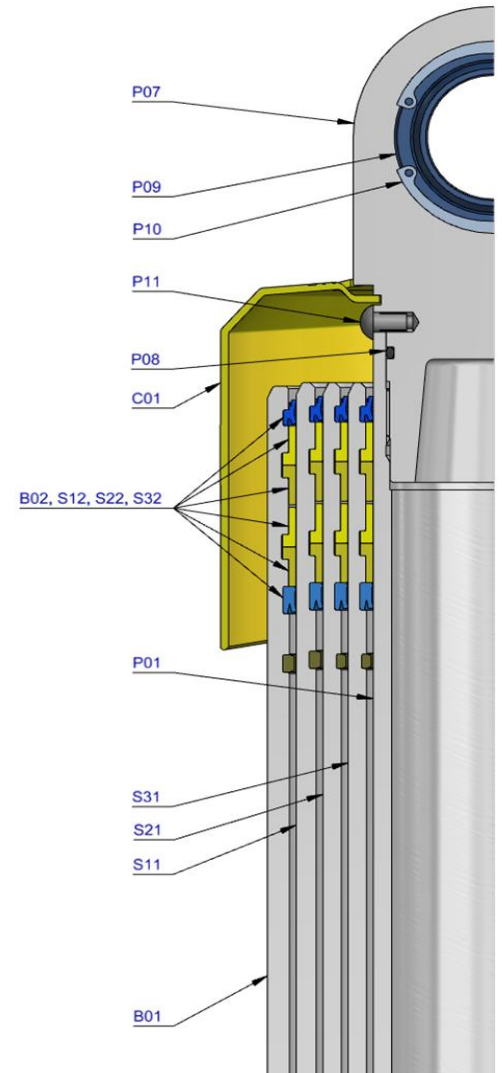

Seal kit complete

71908540K	Consists of all packsets with packset grease and O-rings
-----------	--

Notes

The inner stopring and piston bottom are pre-mounted on spare bases, stage and pistons. Therefore, when ordering new tubes, it is not required to order these parts separately.

For repair instructions see: CYL-0040. Serial no. is located on type plate and near type plate support.