

\* incl. 20 [-5; +30] mm pull out

3D model is available on request or [www.hyva.com](http://www.hyva.com)

Specifications		Max. pump flow		Tipping time	
Max. working pressure	170 bar	With KO <sup>1</sup>	190 L/min	With KO <sup>1</sup>	41 sec
Weight	316 kg	Without KO <sup>1</sup>	170 L/min	Without KO <sup>1</sup>	46 sec
Working volume	130 L	With KO <sup>1</sup> below -20°C	133 L/min	With KO <sup>1</sup> below -20°C	59 sec
Total volume	140 L	Without KO <sup>1</sup> below -20°C	119 L/min	Without KO <sup>1</sup> below -20°C	66 sec
Max. cyl. load (start tipping)	345 kN			Allowable lowering time	41 sec
Max. cyl. load (end of stroke) <sup>2</sup>	119 kN				
Max. cyl. load (end of stroke) <sup>3</sup>	139 kN				

### Technical notes

- This cylinder is a lifting device only. • It should not be used as a structural member and should not be subjected to side loads. • Tipping valve must have a pressure relief at the cylinder port set not higher than max. working pressure. • Verify max. cyl. load. • Working temperature range is between -40°C and +80°C. • Max. duration of extension is 0.5 hours (excluded hard chromed stages). • Cylinder is painted black (RAL9005) with a min. thickness conforming to the 480 hours neutral salt spray test as per ISO 9227. • <sup>1</sup> Hyva knock-off. • <sup>2</sup> Unsubstantial unloading (sticky load). • <sup>3</sup> Substantial unloading.

### Related documentation

Bracket options:	015BRA10 & 015BRA13
Mounting instructions:	CYL-0031
Oil specifications:	OIL-0011
Spec sheet explanation:	CYL-0041

### Configuration

Extension	1	2	3	4	5	6	7	Total
Effective diameter [mm]	191	169	149	129	110			7130
Stroke* [mm]	1410	1430	1430	1430	1430			

### Tipping weight

For detailed tipping calculations please refer to: <https://tipper.hyva.com>

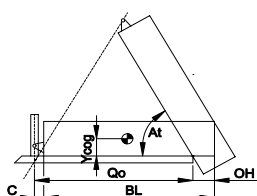

BL body length  
OH rear overhang  
Ycog vert. pos. centre of gravity  
Qo pivot length  
C bracket length  
At tipping angle  
 $stroke \times 60 / Qo$

BL [mm]	9400			9200			9000		
OH [mm]	200	500	800	200	500	800	200	500	800
At [°]	46	47	49	47	48	50	48	50	52
Ycog [mm]	600			900			1200		
	43	46	49	44	47	50	45	48	52
	46	49	53	47	50	54	47	51	56
	49	52	57	50	54	59	51	55	61

Tipping weight [ton] at maximum pressure of 170 bar for a vertically mounted cylinder and C is 158 mm

Pos.	Part no.	Description	Qty.
C01	71839130	DUST COVER FE 169-4/191-5	1
P01	74463651	PISTON FL3 S 110-1645-HC	1
P02	71853110K	SLIDER FL 110 (2 X 1/2) A22	1
P03	71851110K	OUTER STOPRING FL 110 A22	1
P04	71822110	BOTTOM PLATE PISTON FL 110	1
P05	01745050K	CIRCLIP 100 DIN 472 (105.5x3.0)	1
P06	71870220K	O-RING PISTON BOTTOM 110	1
P07	71847300	PISTON EYE SPH. FL3 110 L=075	1
P08	01226538K	O-RING 91.67 X 3.53 MM NBR	1
P09	71875450K	SPHERICAL BEARING D.50.3 MAINT. FREE	1
P10	01770560K	CIRCLIP 75 DIN 472 (79.5x2.5)	1
P11	71875012	PIN ROUND HEAD GROOVED 8x15 mm	2

S41	74604650	STAGE FL2 129-1640	1
S42	71802129K	PACKSET FL 129/HP 129	1
S43	71853129K	SLIDER FL 129 (2 X 1/2) A22	1
S44	71851129K	OUTER STOPRING FL 129 A22	1
S45	71852129K	LIFTRING FL 129 A22	1

S31	74605650	STAGE FL2 149-1640	1
S32	71802149K	PACKSET FL 149/HP 150	1
S33	71807151K	SLIDER FL 149 A35	1
S34	71851149K	OUTER STOPRING FL 149 A22	1
S35	71852149K	LIFTRING FL 149 A22	1

S21	74606650	STAGE FL2 169-1640	1
S22	71802169K	PACKSET FL 169	1
S23	71807171K	SLIDER FL 169 A35	1
S24	71851169K	OUTER STOPRING FL 169 A22	1
S25	71813169K	LIFTRING FL 169x5	1

S11	74607650	STAGE FL2 191-1640	1
S12	71802191K	PACKSET FL 191	1
S13	71807193K	SLIDER FL 191 A35	1
S14	71851191K	OUTER STOPRING FL 191 A22	1
S15	71813191K	LIFTRING FL 191x5	1

B01	74508654	BASE FL2 214-1691-4/4BSAE-290	1
B02	71802214K	PACKSET FL 214	1
B03	71825435	BOTTOM PLATE FL2 214	1
B04	71870045K	SEAL BOTTOM PLATE FL 214	1
B05	71820214	LOCKING PLATE FL 214	3
B06	01732020K	BOLT HEX M12X25X1.25 SET 6 PCS	1
B07	01732523K	WASHER SPRING M12 SET 6 PCS	1

### Seal kit complete

71908750K	Consists of all packsets with packset grease and O-rings
-----------	--

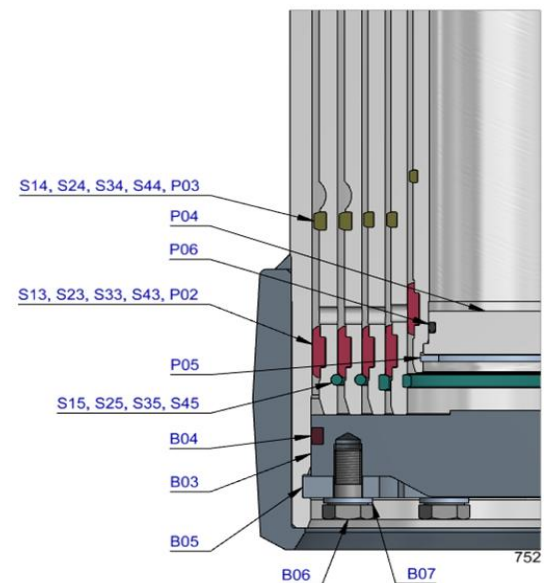
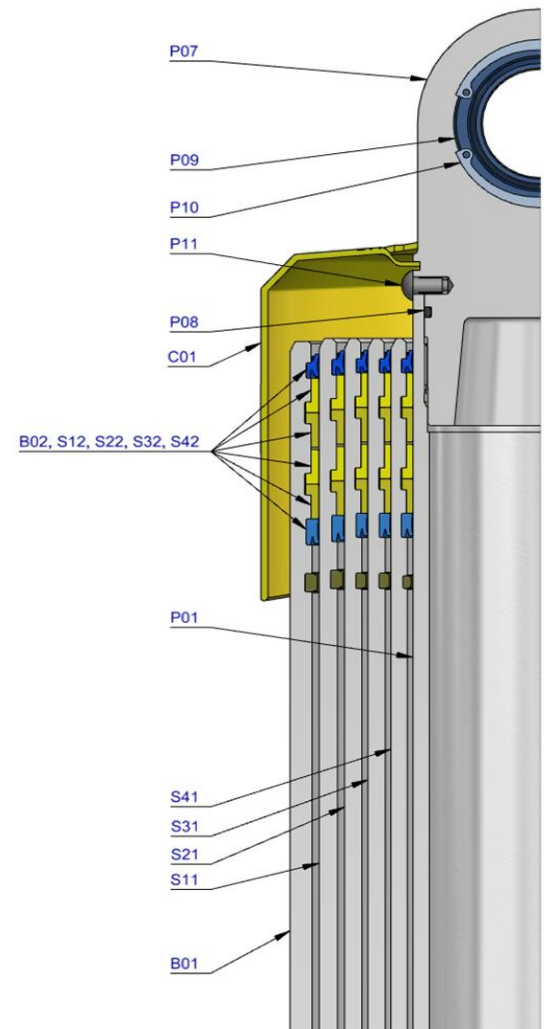

### Notes

The inner stopring and piston bottom are pre-mounted on spare bases, stage and pistons. Therefore, when ordering new tubes, it is not required to order these parts separately.

For repair instructions see: CYL-0040. Serial no. is located on type plate and near type plate support.