

HYVA CYLINDER

714 36 929



type: UME 169-5-3280-K221-50-3/4"-H45-HC

tipping weight: 20-31 ton

page # 1 / 1

Stage diameters	front view cylinder		A	230
169			ØC	192
149			G¹	987
129			I	731
110			K¹	221
91			H¹	62
		N	35	
		ØP	88	
		ØY	45.5	
		S	540	
		ØW	50	
		X	45	

¹including 20 mm pull-out [tol. -5; +30 mm]

²cylinder is delivered including oil inlet swivel adapter

specifications

total stroke ¹	3280 mm
dry weight cylinder only	149 kg
total volume	48.9 L
working volume	45.2 L
maximum pressure	220 bar
maximum pump flow	98 l/min
maximum allowable thrust first stage ³	25.0 ton
oil inlet	3/4" BSP

technical notes

This cylinder is a lifting device only and may not be used as a structural member or be subjected to side load. Sideload and/or poor alignment might result in cylinder leakage. Hyva therefore strongly recommends the use of a cradle, even in instances where the cylinder only tips to the rear or to the side. The cylinder is painted black RAL9005. For suitable hydraulic oils, please refer to data sheet OIL-0011. For details of available brackets and cradles, please refer data sheet 015BRA06. Detailed calculations can be made using the HYVA Tipper Program, freely available from tipper.hyva.com.

³The cylinder thrust on the first stage (from the HYVA Tipper Program) must not exceed the maximum allowable (see specifications above).

tipping view

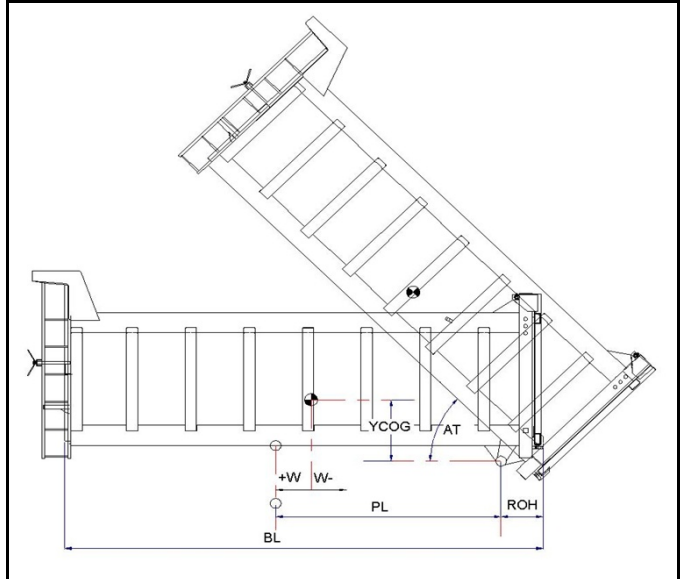

tipping weight

PL	4280	mm	3780				
YCOG	700	mm	700				
ROH	700	mm	700				
BL	9960	9050	8300	mm	8960	8150	7470
CYL w.r.t. COG (W)	0	450	830	mm	0	410	750
Tipping weight for full stroke of 46°				Tipping weight for full stroke of 52°			
Tipping weight	20	22	25	ton	21	24	28
Tipping weight for second last stage, up to 37°				Tipping weight for 2nd last stage, up to 42°			
Tipping weight	25	28	31	ton	25	28	31

HYVA CYLINDER

714 36 929

type UME 169-5-3280-K221-50-3/4"-H45-HC

page # 2 / 2

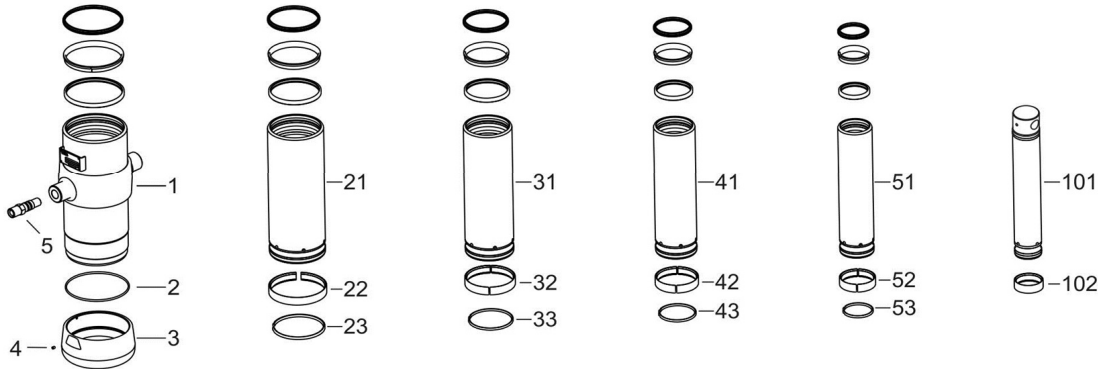

Spare part list

Pos	Part no.	Description	Qty.
1	73507950	BASE 191-0862-N0159	1
2	01226780	O-RING 184 X 4 NBR 70 SHORE A	1
3	73101050	THREADED BOTTOM UM 191	1
4	01792571	LOCKING SCREW M6X12 INT. HEX. DIN 916	1
5	73103002	OIL INLET ADAPTOR UM 3/4"OT+O-RING	1
21	73606951	STAGE 169-0862-HC	1
22	71807169 K	SLIDER FL 169	1
23	71813169 K	LIFTRING FL 169x5	1
31	73605951	STAGE 149-0862-HC	1
32	71807149 K	SLIDER FL 149	1
33	71812149 K	LIFTRING FL 149/HP 150	1
41	73604951	STAGE 129-0862-HC	1
42	71807129 K	SLIDER FL 129/GF 129 (2 X 1/2)	1
43	71812129 K	LIFTRING FL 129/HP 129	1
51	73603951	STAGE 110-0862-HC	1
52	71807110 K	SLIDER FL 110/GF 110 (2 X 1/2)	1
53	71812110 K	LIFTRING FL 110	1

Spare part list

Pos	Part no.	Description	Qty.
101	73432955	PISTON E 091-0862-H45-HC (SR=450)	1
102	71807091 K	SLIDER FL 091 (2 X 1/2)	2

Seal kit complete

Part no.	Description
719 04 651K	Complete packset: Consists of all packsets with packset grease and o-ring.