

HYVA CYLINDER

714 35 625



type: UME 149-4-2180-K221-50-3/4"-HC

tipping weight: 20-32 ton

page # 1 / 1

Stage diameters 149 129 110 91	front view cylinder		<table border="0"> <tr><td>A</td><td>205</td></tr> <tr><td>ØC</td><td>170</td></tr> <tr><td>G¹</td><td>787</td></tr> <tr><td>I</td><td>531</td></tr> <tr><td>K¹</td><td>221</td></tr> <tr><td>H¹</td><td>62</td></tr> <tr><td>N</td><td>35</td></tr> <tr><td>ØP</td><td>88</td></tr> <tr><td>ØY</td><td>45.5</td></tr> <tr><td>S</td><td>538</td></tr> <tr><td>ØW</td><td>50</td></tr> <tr><td>X</td><td>45</td></tr> </table>	A	205	ØC	170	G ¹	787	I	531	K ¹	221	H ¹	62	N	35	ØP	88	ØY	45.5	S	538	ØW	50	X	45
A	205																										
ØC	170																										
G ¹	787																										
I	531																										
K ¹	221																										
H ¹	62																										
N	35																										
ØP	88																										
ØY	45.5																										
S	538																										
ØW	50																										
X	45																										

¹including 20 mm pull-out [tol. -5; +30 mm]

²cylinder is delivered including oil inlet swivel adapter

specifications

total stroke ¹	2180 mm
dry weight cylinder only	94 kg
total volume	27.5 L
working volume	25.3 L
maximum pressure	220 bar
maximum pump flow	98 l/min
maximum allowable thrust first stage ³	25.0 ton
oil inlet	3/4" BSP

technical notes

This cylinder is a lifting device only and may not be used as a structural member or be subjected to side load. Sideload and/or poor alignment might result in cylinder leakage. Hyva therefore strongly recommends the use of a cradle, even in instances where the cylinder only tips to the rear or to the side. The cylinder is painted black RAL9005. For suitable hydraulic oils, please refer to data sheet OIL-0011. For details of available brackets and cradles, please refer data sheet 015BRA06. Detailed calculations can be made using the HYVA Tipper Program, freely available from tipper.hyva.com.

³The cylinder thrust on the first stage (from the HYVA Tipper Program) must not exceed the maximum allowable (see specifications above).

tipping view

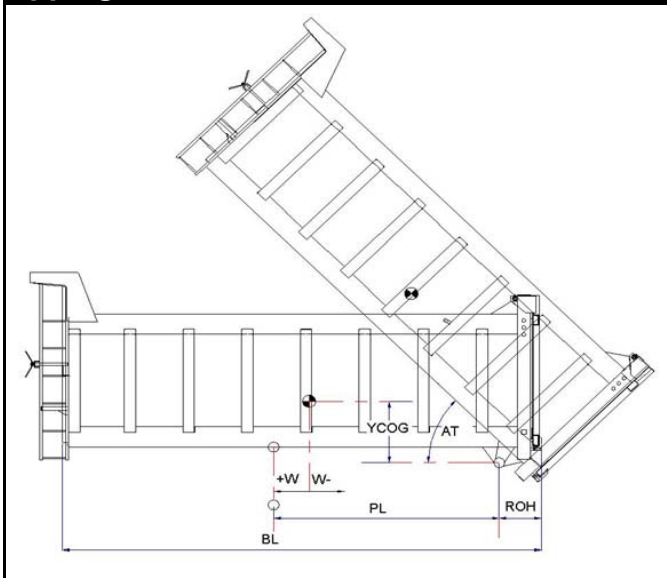

tipping weight

PL	2840	mm	2520				
YCOG	600	mm	600				
ROH	600	mm	600				
BL	6880	6250	5730	mm	6240	5670	5200
CYL w.r.t. COG (W)	0	310	570	mm	0	280	520
Tipping weight for full stroke of 46°				Tipping weight for full stroke of 52°			
Tipping weight	20	23	26	ton	21	25	28
Tipping weight for second last stage, up to 35°				Tipping weight for 2nd last stage, up to 39°			
Tipping weight	25	28	31	ton	25	28	32

HYVA CYLINDER

714 35 625

type

UME 149-4-2180-K221-50-3/4"-HC

page # 2 / 2

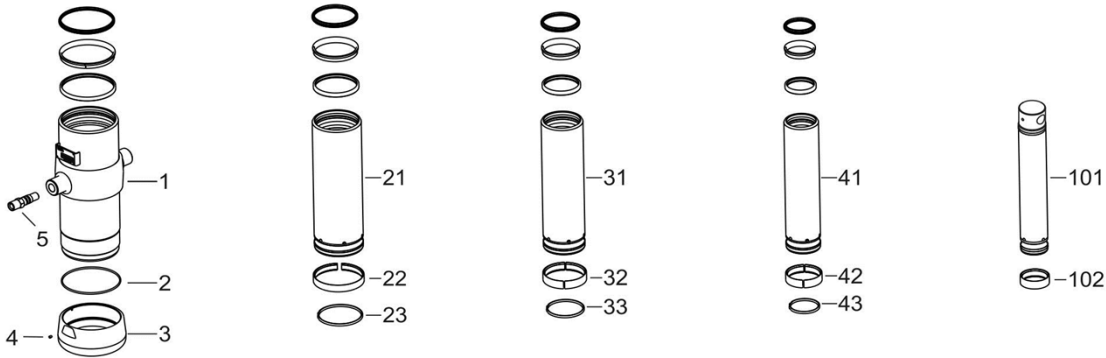

Spare part list			
Pos	Part no.	Description	Qty.
1	73506800	BASE 169-0662-N0159	1
2	01226709	O-RING 165 X 4 NBR 70 SHORE	1
3	73101040	THREADED BOTTOM UM 169	1
4	01792571	LOCKING SCREW M6X12 INT. HEX. DIN 916	1
5	73103002	OIL INLET ADAPTOR UM 3/4"OT+O-RING	1
21	73605801	STAGE 149-0662-HC	1
22	71807149 K	SLIDER FL 149	1
23	71812149 K	LIFTRING FL 149/HP 150	1
31	73604801	STAGE 129-0662-HC	1
32	71807129 K	SLIDER FL 129/GF 129 (2 X 1/2)	1
33	71812129 K	LIFTRING FL 129/HP 129	1
41	73603801	STAGE 110-0662-HC	1
42	71807110 K	SLIDER FL 110/GF 110 (2 X 1/2)	1
43	71812110 K	LIFTRING FL 110	1

Spare part list			
Pos	Part no.	Description	Qty.
101	73432803	PISTON E 091-0662-H45-HC	1
102	71807091 K	SLIDER FL 091 (2 X 1/2)	1

Seal kit complete	
Part no.	Description
719 04 541K	Complete packset: Consists of all packsets with packset grease and o-ring.