

- 1 P Pump connection (P)
- 2 T Tank connection (T)
- 3 C Cylinder connection SAE (C)
- 4 Pneumatic connection (Tip) 6 mm
- 5 Pneumatic connection (Lower) 6 mm
- 6 Pressure relief cartridge
- 7 MPC Pressure gauge point (MPC)
(Pressure gauge point)
- 8 Adjustment screw (int.hex. 5)
(To adjust the lowering speed)

SAFETY:

HT valve fitted on cylinder (SAE) port provides hose burst safety function

Types

Hydraulic connections	Pressure (bar)	Part Number	Description
	Max.		
P: G3/4" T: G1" C: SAE MPC: G1/4"	135	14767452	TIP VALVE HT-SAE-1220-135-P3/4"
	150	14767454	TIP VALVE HT-SAE-1220-150-P3/4"
	170	14767456	TIP VALVE HT-SAE-1220-170-P3/4"
	190	14767458	TIP VALVE HT-SAE-1220-190-P3/4"
	220	14767460	TIP VALVE HT-SAE-1220-220-P3/4"
	250	14767462	TIP VALVE HT-SAE-1220-250-P3/4"
P: G1" T: G1" C: SAE MPC: G1/4"	135	14767453	TIP VALVE HT-SAE-1220-135-P1"
	150	14767455	TIP VALVE HT-SAE-1220-150-P1"
	170	14767457	TIP VALVE HT-SAE-1220-170-P1"
	190	14767459	TIP VALVE HT-SAE-1220-190-P1"
	220	14767461	TIP VALVE HT-SAE-1220-220-P1"
	250	14767463	TIP VALVE HT-SAE-1220-250-P1"

Mounting kits	Kit number
Cylinder (SAE)*	14735175

* included with valve

Specifications

Type	3/3 pneumatic operated tipping valve with proportional lowering	
Max. pump flow	220	L/min
Max. pressure	350	bar
Pneumatic pilot pressure	6 - 12	bar
Max. pressure on T-connection	10	bar
Min. filtration	25	µm
Viscosity range min / max	12 / 100	mm ² /s (cSt)
Max. starting viscosity	1500	mm ² /s (cSt)
Temperature range min / max	-40 / 80	°C
Mass	5.5	kg

Δp - Q characteristic

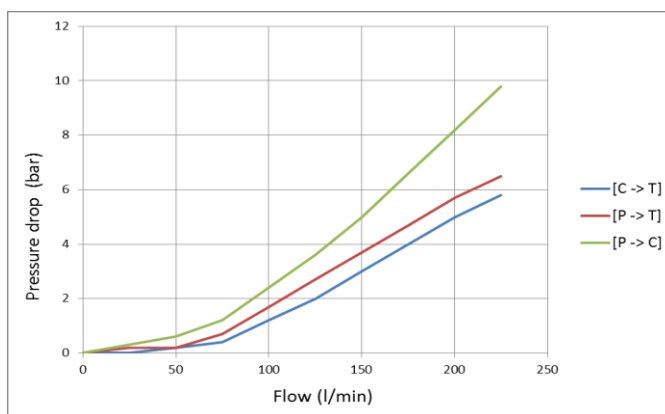

Technical notes

· Mount the valve according the mounting instructions · Use the correct washers and adapters in the ports to prevent deformation of the housing. Do not use adapters with tapered threads · To further prevent deformation of the valve housing, the mounting plate surface or block must be completely flat and smooth · Do not weld to the valve · Ideal air pressure for valve is 8 bar · Make sure inlet air is dry and clean · Painted black (RAL9005)

Related documentation

Mounting instructions: VAL-0021

Oil specifications: OIL-0011

Mounting kit

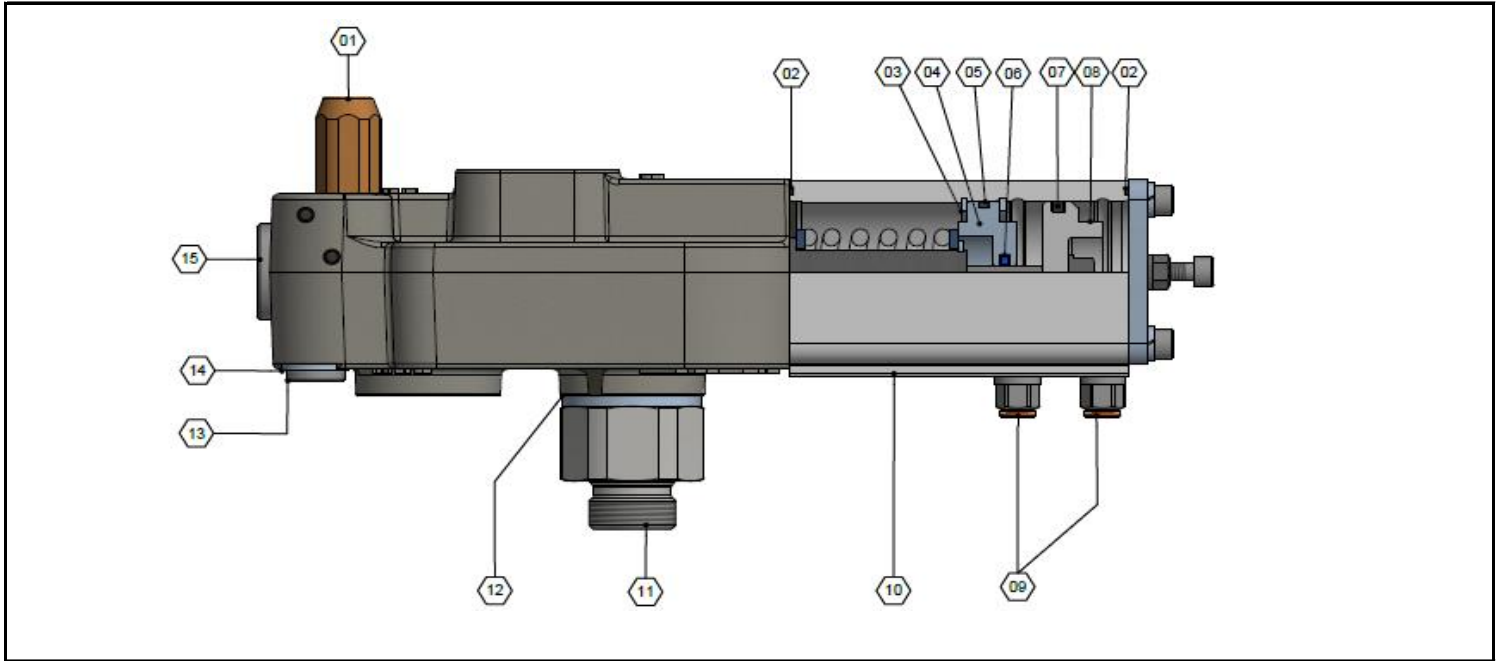

Spare Parts

No.	Part no.	Description	Qty.
1	14772__	Pressure relief cartridge	1
	135	135 bar	
	150	150 bar	
	170	170 bar	
	190	190 bar	
	220	220 bar	
	250	250 bar	
2	n.a; see repair kit	O-ring	2
3	n.a; see repair kit	Circlip	2
4	n.a; see repair kit	Closing plate	1
5	n.a; see repair kit	O-ring	1
6	n.a; see repair kit	Quadring	1
7	n.a; see repair kit	Quadring	1

No.	Part no.	Description	Qty.
8	n.a.	Piston air cylinder	1
9	14810517	Air coupling 6 mm	2
10	n.a; see repair kit	Aluminium head	1
11	14739980	Non-return valve 3/4"	1
11	14739975A	Non-return valve 1"	1
12	01313848	Bonded seal 1"	1
13	n.a.	Plug 1/4"	1
14	01206813	Bonded seal 1/4"	1
15	n.a.	Plug M27	1

Repair kits

	14844010	Seal kit (contains pos. 2, 5, 6, 7)
	14845003	Air cylinder kit (contains pos. 3, 4, 5, 6, 10)

Hydraulic symbol HT valve

